

Healthier Cabinetry Guide

Healthy Materials Lab

The Healthy Materials Lab at Parsons School of Design is dedicated to a world with human health at the center of all design decisions.

We're committed to raising awareness about toxics in building products, and to creating resources for the next generation of designers and architects—all in order to make healthier places for people to live.

Alison Mears
Director

Jonsara Ruth
Director of Design

Leila Behjat
Senior Researcher

Sam Bennett
Senior Researcher

Ava Robinson
Copy Editor

Hana Wilson
Student Research Assistant

© 2021 Healthy Materials Lab
Parsons School of Design,
The New School

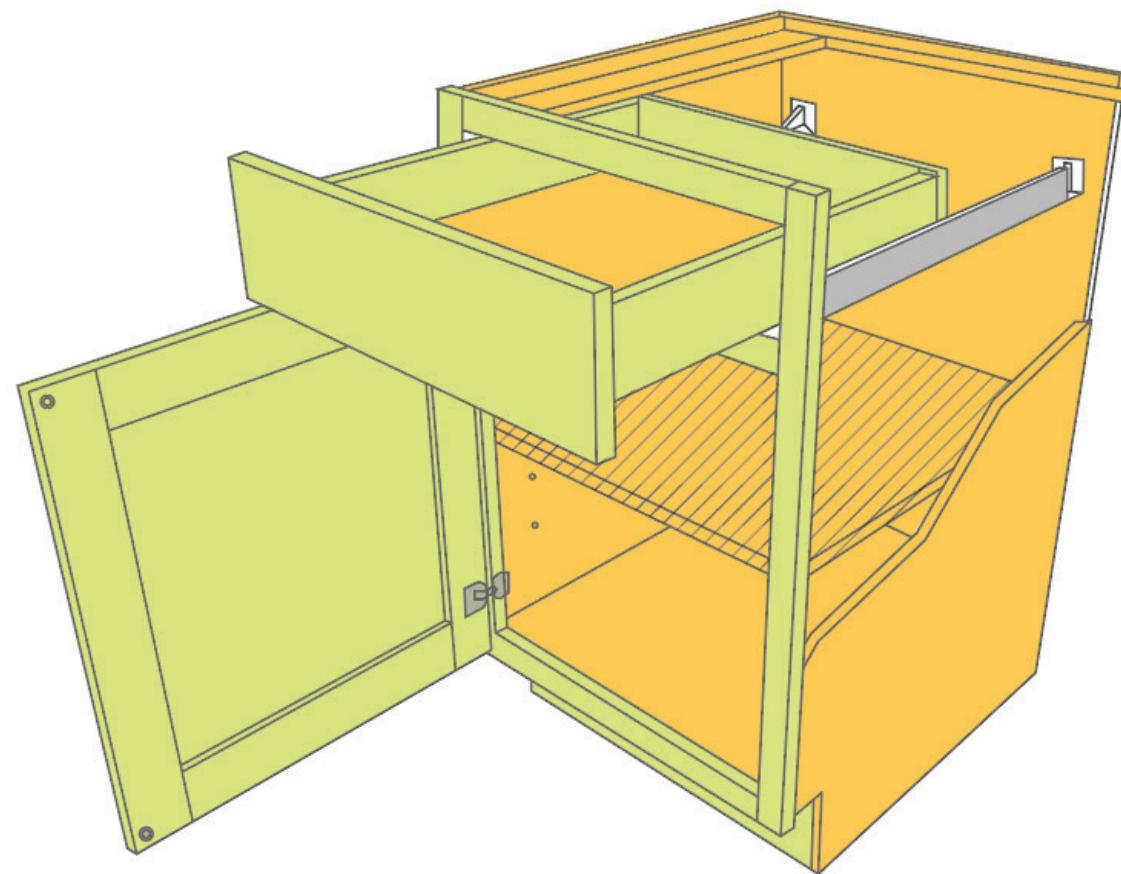
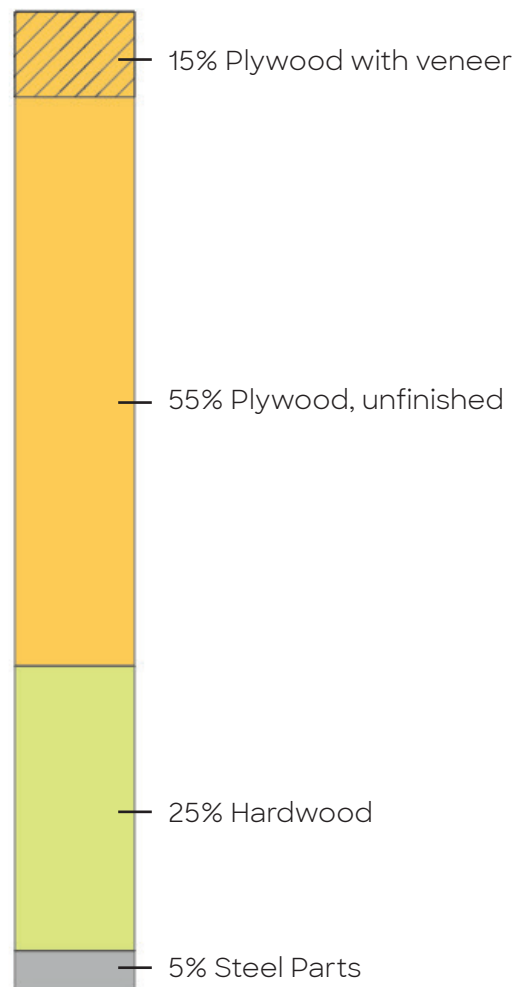

Introduction

At face value, cabinetry may seem to be made of one type of wood, but its construction is much more complex. Many prefabricated cabinets are built using a combination of three or more wood composites and veneers, which typically use toxic glues containing **formaldehyde**, a known human carcinogen.

By comparing the material contents and construction in prefabricated cabinets, we created a spectrum that indicates the **relationship between affordability and health**. We typically consider the health effects during all phases of product development, but these diagrams are focused on the health effects during installation and inhabitation.

Currently, prefabricated cabinets are composed of 5%-30% healthier materials. Designers can increase this percentage by requesting manufacturers to build with NAF (no added formaldehyde) composite woods. This often comes with an increased price. Our [Composite Wood Product and Spec Guidance](#) gives a range of healthier substitutions.



Spec Guidance

Substrates for Cabinet Boxes, Framing, and Shelving

- Choosing solid wood for framing avoids the use of resins or binders in panels altogether, eliminating concerns of formaldehyde or other potential toxics.
- Specify products that meet the NAF Standard for No Added Formaldehyde. This is currently the highest federal standard regulating formaldehyde. If NAF is not an option, consider products that are labeled as Ultra-Low Emitting Formaldehyde (ULEF). Although not held to as strict as NAF products, these options are still preferable to those that use standard formaldehyde-based resins.
- Be mindful of the amount of binder. Because binders contain most of the formaldehyde in composite wood products, less binder means less toxic content. **Plywood tends to have the lowest amount** (3.5% by weight), while MDF, HDF, and particleboard have much higher concentrations, 10%, 11.4%, and 12.4% respectively ([HomeFree](#)).
- Look for soy-based binders. Methylene diisocyanate (MDI) resins are a regrettable substitution for formaldehyde and can still be hazardous to workers ([HomeFree](#)).

Faces and Edge Banding (Interior and Exterior)

- Use solid wood for cabinet faces. Solid wood avoids the need for resins or binders altogether, eliminates concerns of formaldehyde or regrettable substitutions.
- Consider hardwood veneers for cabinet faces instead of laminates like thermofused melamine, which emit formaldehyde over time.
- Avoid thermofoil veneers and edge-banding containing polyvinyl chloride (PVC) when possible. PVC is a known human carcinogen and contains harmful plasticizers such as phthalates that can disrupt our body's endocrine system which regulates hormones.

- **Avoid thermofused melamine veneers** when possible. They are impregnated with resin containing formaldehyde, which emit VOCs over time ([Home Free](#)).
- **Consider long term maintenance.** Solid wood or hardwood veneers allow for refinishing, unlike thermofoil and thermofused veneers which can chip, peel, and bubble over normal wear and cannot be easily repaired.

Stains and Coatings

- **Choose water-based finishes with a transparent ingredient list.** Otherwise, the tracing of hazards in lacquers and varnishes is difficult.
- Avoid hazards like high VOC levels, phthalates, flow aids containing PFCs, and n-methyl-2-pyrrolidone (NMP), which is common in polyurethane and is a fetal toxin.
- **Look out for commonly required solvents** which can have high VOC levels. Xylene or toluene, which are carcinogenic, are often used.
- **Look out for toxic drying agents.** Raw linseed oil has a long curing time. To accelerate this, manufacturers add drying agents to create polymerized or boiled linseed oil (BLO). Historically, carcinogenic heavy metals (e.g., arsenic, beryllium, chromium, cadmium, nickel, and lead) have been used as drying agents. Cobalt is used as an alternative but is an aquatic toxic and should be avoided as well.
- **Avoid accelerators.** Typically offered as one part of a 2-component formula, accelerators shorten curing time. However, they may contain toxic ingredients like isocyanates.
- **Choose oil finishes without harmful additives.** Products like purified linseed oil and tung oil are healthier alternatives to water-based synthetic finishes. **But check the SDS.** Some manufacturers sell products under these names that aren't completely natural and include carcinogenic petroleum distillates.

- **Pure tung oil cures more quickly** than linseed oil so it does not require drying agents.
- **Consider alternative finishing methods.** Shou Sugi Ban, a Japanese technique, creates a beautiful, durable finish on wood by charring it with fire.
- **Look for paints that meet the Green Seal-11 (GS-11) standard from 2010 or later.** This certification limits the content of VOCs and prohibits other potential hazards such as heavy metals, carcinogens, mutagens, and reproductive toxins. Check out our [spec guidance for paint here](#).

Additional Construction Considerations

- **Design for disassembly** using screws and dowels instead of binding with wood glue. All current wood glue in the market emit VOCs, although some less than others. Reducing the amount of glue is both healthier and allows for materials to be disassembled more easily for reuse.
- **Use interlocking joinery** like dovetailed drawers for strength and longevity.
- **Not all hardware is created equally.** Specify higher quality brands (like Blum glides) to increase the cabinet's lifespan.
- **Kitchen cabinets are often the first point of entry for pests.** Refer to the [Pest Prevention by Design manual](#) for construction techniques used to prevent pests from entering the kitchen without the need to use unhealthy pesticides. For example, ensure there are no openings in the back of cabinet boxes to let in mice, rats, and roaches.

Materials For Cabinetry Health Spectrum

These diagrams explore the complexities of cabinetry construction. They analyze a range of typical cabinetry materials and how these materials come together through the lenses of human health and affordability.

This spectrum is organized based on each product's material contents and how it affects human health during the installation and inhabitation phase. The spectrum moves from more harmful materials on the left to healthier materials on the right. To understand how material health correlates with affordability in cabinetry construction, turn to page 6.

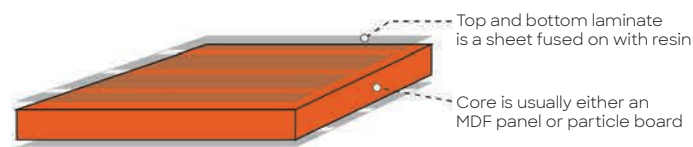

Thermofused Melamine

Thermofused Melamine is paper saturated with formaldehyde resin and fused onto MDF (medium-density fiberboard) or particle board. This panel is usually very inexpensive, but has significant health risks associated with the application of formaldehyde resin.

Health impacts:

Formaldehyde is a colorless gas (one of the most common VOCs). Phenol formaldehyde, urea formaldehyde, and melamine formaldehyde are all known to release (off-gas) formaldehyde long after product installation. Formaldehyde exposure is linked to myeloid leukemia and rare cancers, eye and nose irritation, lung irritation, and skin irritation like eczema.

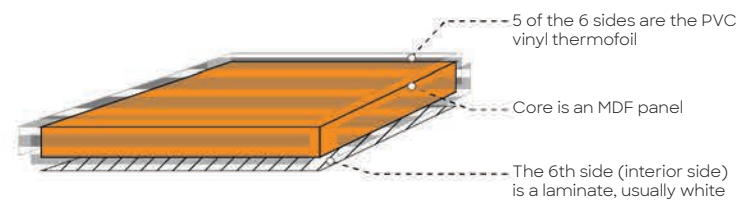

Thermofoil

Thermofoil is a thin layer of vinyl (PVC) that is vacuum-pressed on MDF. With Thermofoil, you will only be able to cover 5 of the 6 sides of the cabinet door. This generally means that the backside of the cabinet doors will be a neutral-colored laminate that will not match the rest of the door. Toxics can be found in both the vinyl and the binder of the MDF core.

Health impacts:

Polyvinyl Chloride (PVC) is a known human carcinogen and contains harmful plasticizers such as phthalates that can disrupt the endocrine system, the body's system of regulating hormones. Phthalates are linked to childhood asthma and allergies, ADHD, low sperm count and low testosterone, male genital birth defects, early puberty in girls, and higher breast cancer risk.

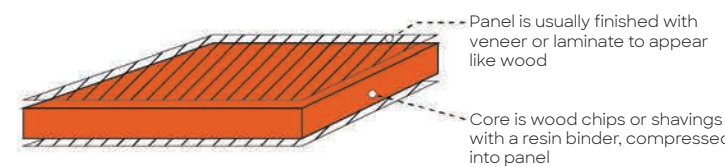

Particle Board

Particle board is made from wood chips or shavings (thicker particles than used in MDF board), combined with a resin or glue binder, and compressed into panels. Particleboard is less dense and usually cheaper than MDF board. It is often finished with veneer or laminate. This product is unhealthy because of formaldehyde contained in the binders.

Health impacts:

Formaldehyde is a colorless gas (one of the most common VOCs). Phenol formaldehyde, urea formaldehyde, and melamine formaldehyde are all known to release (off-gas) formaldehyde long after product installation. Formaldehyde exposure is linked to myeloid leukemia and rare cancers, eye and nose irritation, lung irritation, and skin irritation like eczema.

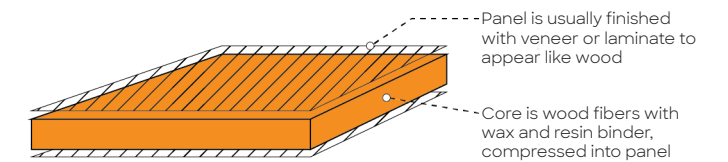

MDF Board

Medium-Density Fiberboard (MDF) is made by breaking down softwood or hardwood residuals into wood fibers, combining it with wax and, most commonly, toxic Urea-formaldehyde (UF) resin. It is then cured with heat and pressure and pressed into panels. In most cases, binders in MDF are forms of polyurethane (TDI, HDI, MDI or PMDI) which contain isocyanates.

Health impacts:

Formaldehyde is a colorless gas (one of the most common VOCs). Phenol formaldehyde, urea formaldehyde, and melamine formaldehyde are all known to release (off-gas) formaldehyde long after product installation. Formaldehyde exposure is linked to myeloid leukemia and rare cancers, eye and nose irritation, lung irritation, and skin irritation like eczema.

Isocyanates are powerful irritants to the mucous membranes of the eyes and gastrointestinal and respiratory tracts. These chemicals are linked to cancer as well as respiratory illnesses.

Least Healthy

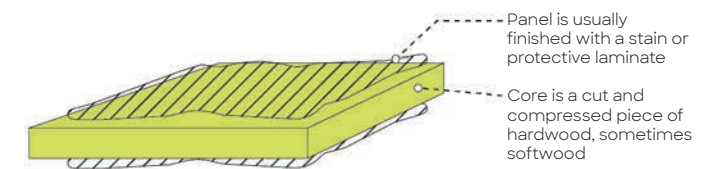
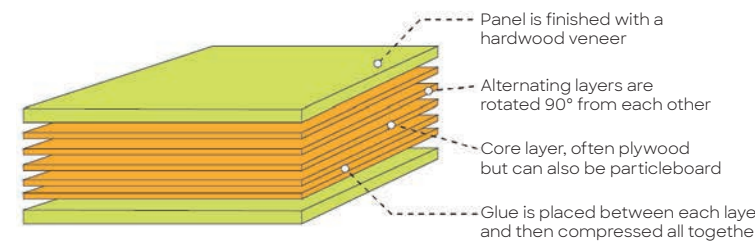
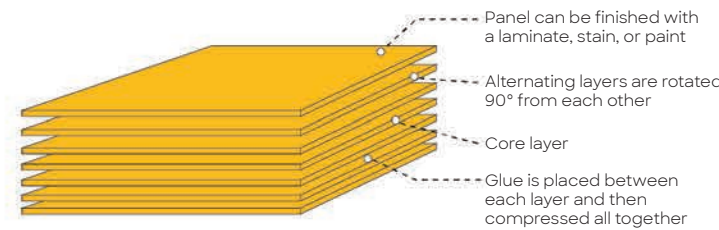
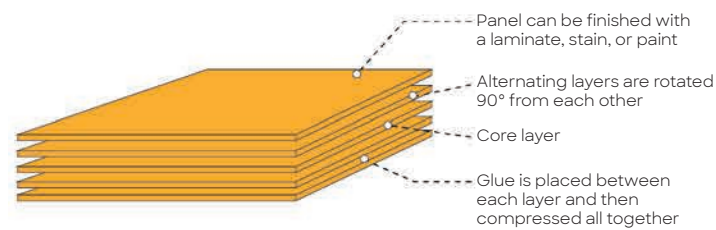

Plywood

Plywood is made up of numerous layers of thin wood veneer that are glued together and compressed. For cabinetry there is often a 1/30" thick face veneer. For stability, each layer is rotated 90° from the one beneath it. The greater the number of layers, the more durable and more expensive the plywood is. It can be considered unhealthy if the binder contains **formaldehyde**. Compared to other composite wood products plywood tends to have the lowest amount of binders (3.5% by weight), while MDF and particleboard have much higher concentrations (10% and 12.4% respectively). Plywood containing soy-based binders are available as a healthier substitution.

Health impacts:

Formaldehyde is a colorless gas (one of the most common VOCs). **Phenol formaldehyde**, **urea formaldehyde**, and **melamine formaldehyde** are all known to release (off-gas) formaldehyde long after product installation. Formaldehyde exposure is linked to myeloid leukemia and rare cancers, eye and nose irritation, lung irritation, and skin irritation like eczema.

Multiply

Multiply is a catchall term for plywood with seven or more layers of wood veneer. It is made by compressing more layers together with glue or resin. For stability, each layer is rotated 90° from the one beneath it. Like plywood, it can remain unfinished or finished with laminate, stain, or paint. It can be considered unhealthy if the binder contains **formaldehyde**. Multiply containing soy-based binders are available as a healthier substitution.

Health impacts:

Formaldehyde is a colorless gas (one of the most common VOCs). **Phenol formaldehyde**, **urea formaldehyde**, and **melamine formaldehyde** are all known to release (off-gas) formaldehyde long after product installation. Formaldehyde exposure is linked to myeloid leukemia and rare cancers, eye and nose irritation, lung irritation, and skin irritation like eczema.

Hardwood-Plywood

Hardwood-Plywood is usually made of a plywood core that is compressed between 1/8" thick hardwood veneer. The core can sometimes be particle board or MDF board. Because of the thicker hardwood veneer, this material is more durable and can be refinished, but is also more expensive. Plywood with particle board or MDF board core can make it less expensive, but an MDF core is heavier and less malleable. As with other composite wood products, binders used are typically toxic resins containing formaldehyde.

Health impacts:

Formaldehyde is a colorless gas (one of the most common VOCs). **Phenol formaldehyde**, **urea formaldehyde**, and **melamine formaldehyde** are all known to release (off-gas) formaldehyde long after product installation. Formaldehyde exposure is linked to myeloid leukemia and rare cancers, eye and nose irritation, lung irritation, and skin irritation like eczema.

Solid Wood

A solid wood panel comprises of a core made from either softwood or hardwood which can be faced and backed with a stain. It is very strong and durable, but also one of the more expensive materials for cabinetry. It's often only used as the framing and facing of cabinetry, but it has the potential to be used more widely. In addition, consider **FSC**-certified options to support sustainable forestry practices.

Health impacts:

Solid wood is the healthiest option available, but as finishes also impact health, healthier finishes must be considered. Solid wood has minimal negative health impacts if it is finished without harmful additives that can be found in solvents or accelerators for dry times. Possible health impacts of long exposure are linked to cancer and asthma. Read our [alternative finishes spec guidance here](#).

Healthier

Cabinetry Affordability Spectrum

This spectrum is organized based on estimated expense of prefabricated cabinetry. The most affordable cabinetry in this comparison begins on the left and shifts towards more expensive on the right. Some of the most affordable cabinets also have the shortest lifespan. To understand how cabinetry construction and material composition affect lifespan, look at the individual cabinetry pages.

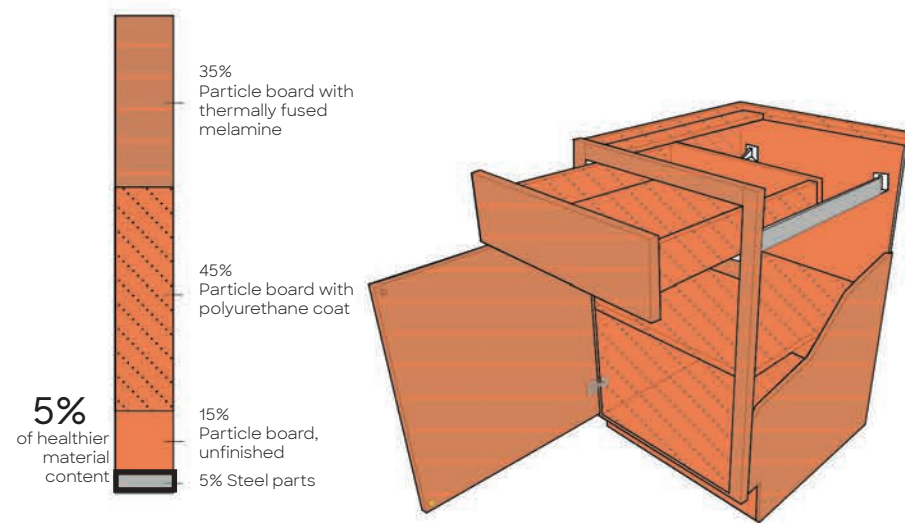

Thermofused Melamine Cabinetry

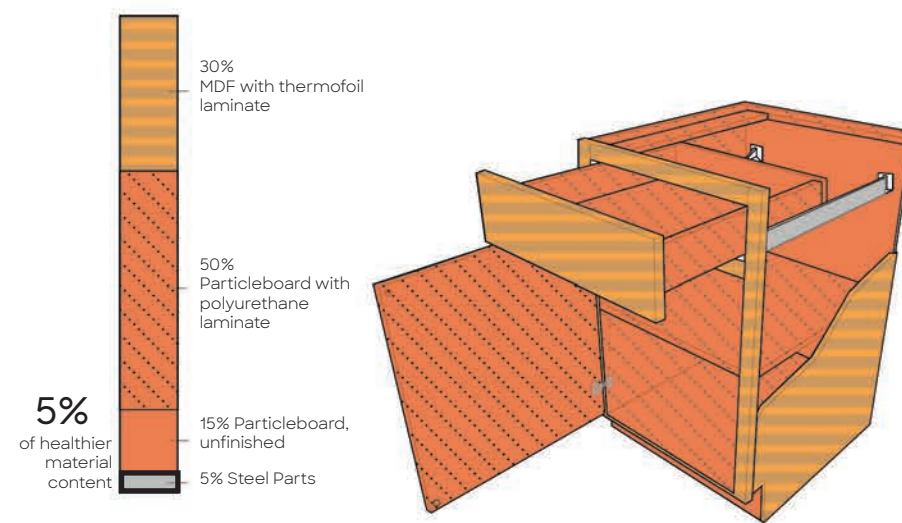

Thermofoil Laminate Cabinetry

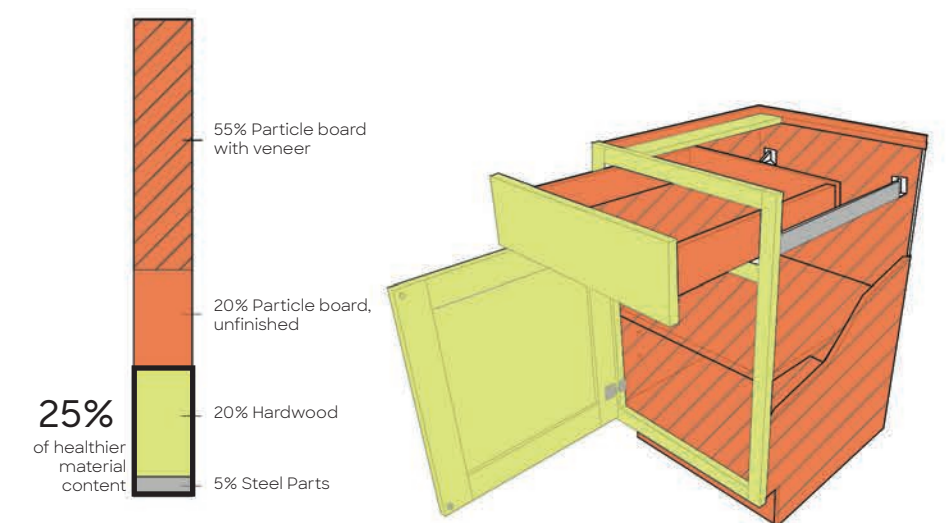

Particle Board Cabinetry

Least Expensive

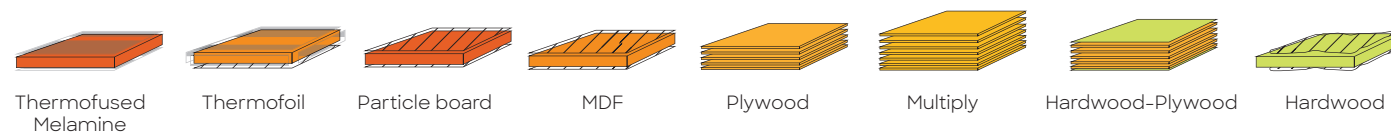

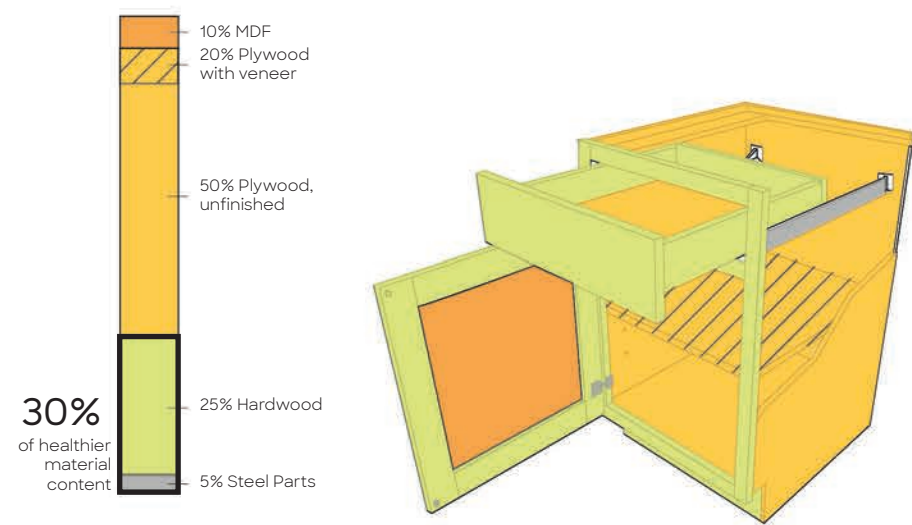

Plywood Cabinetry

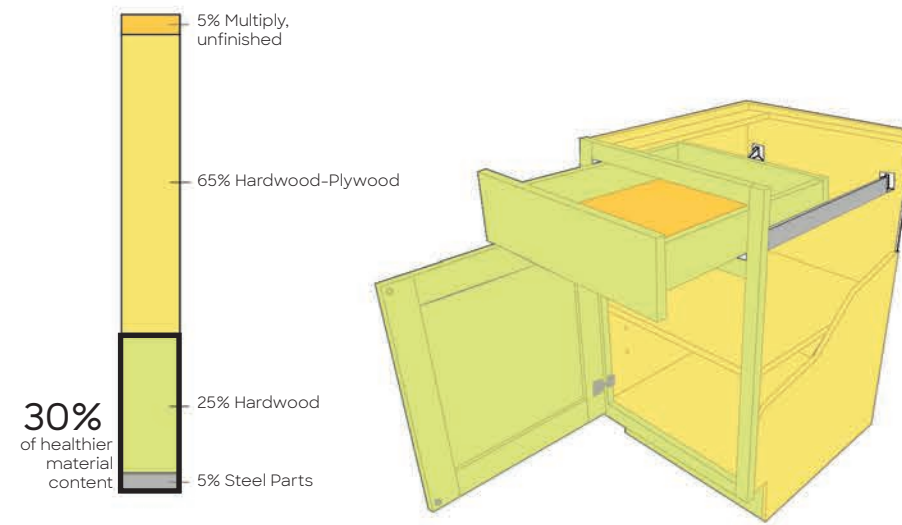

Durable Cabinetry

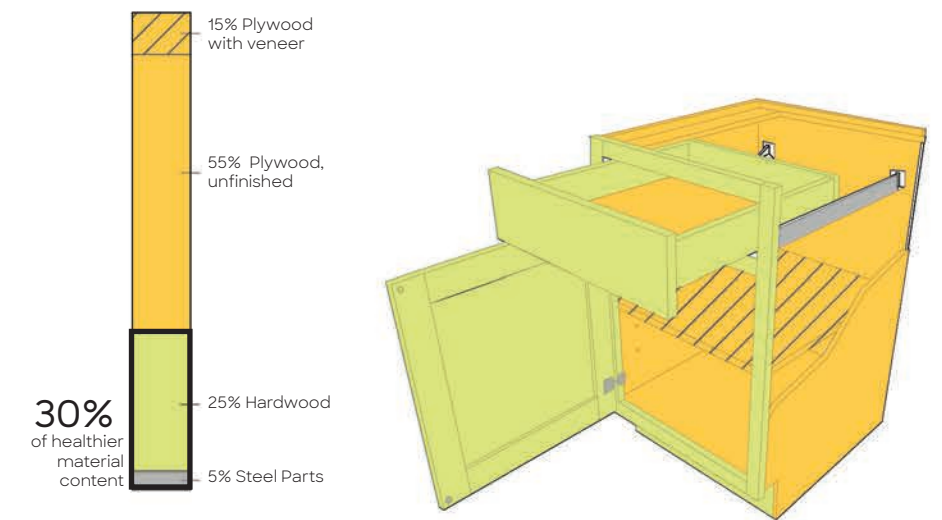

Hardwood Cabinetry

\$\$\$\$

Most Expensive

Percentage of Healthier Materials in Cabinetry

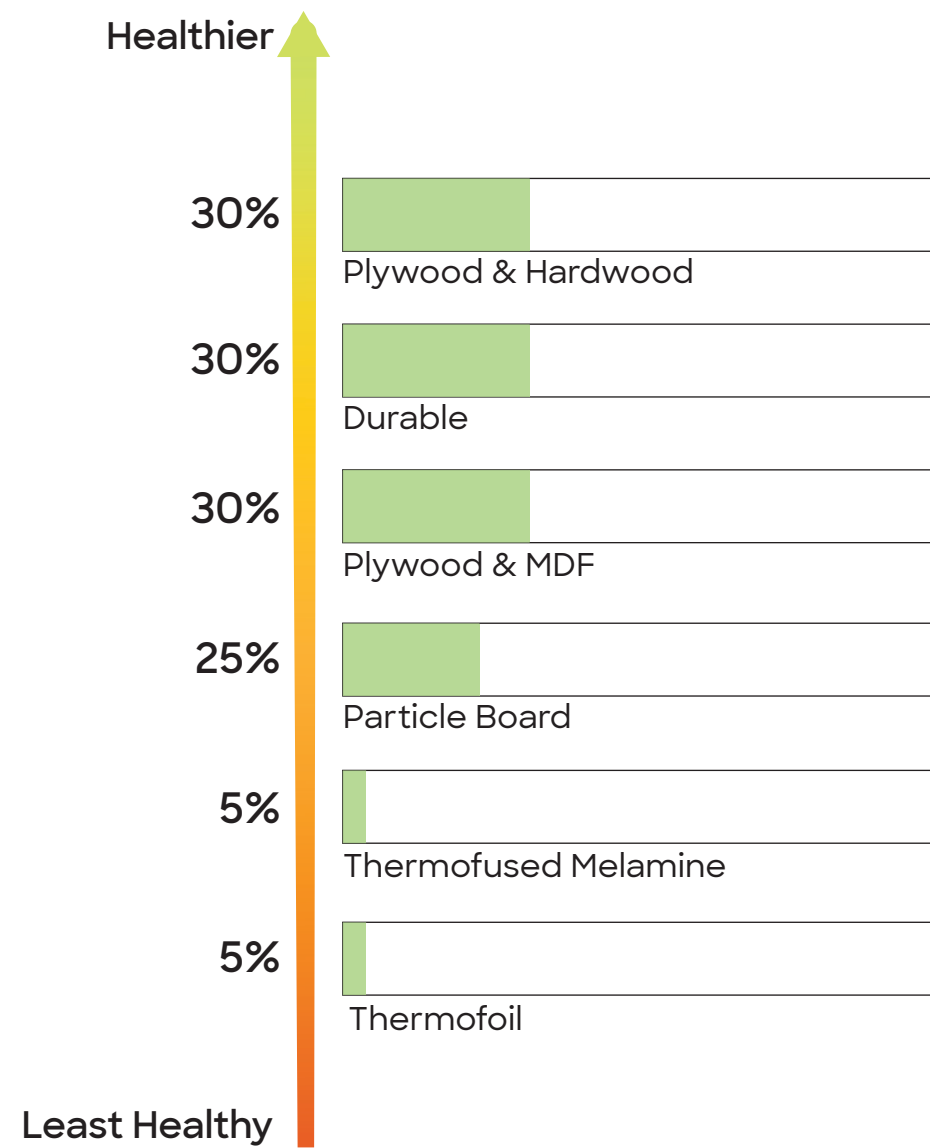

Health & Affordability Matrix

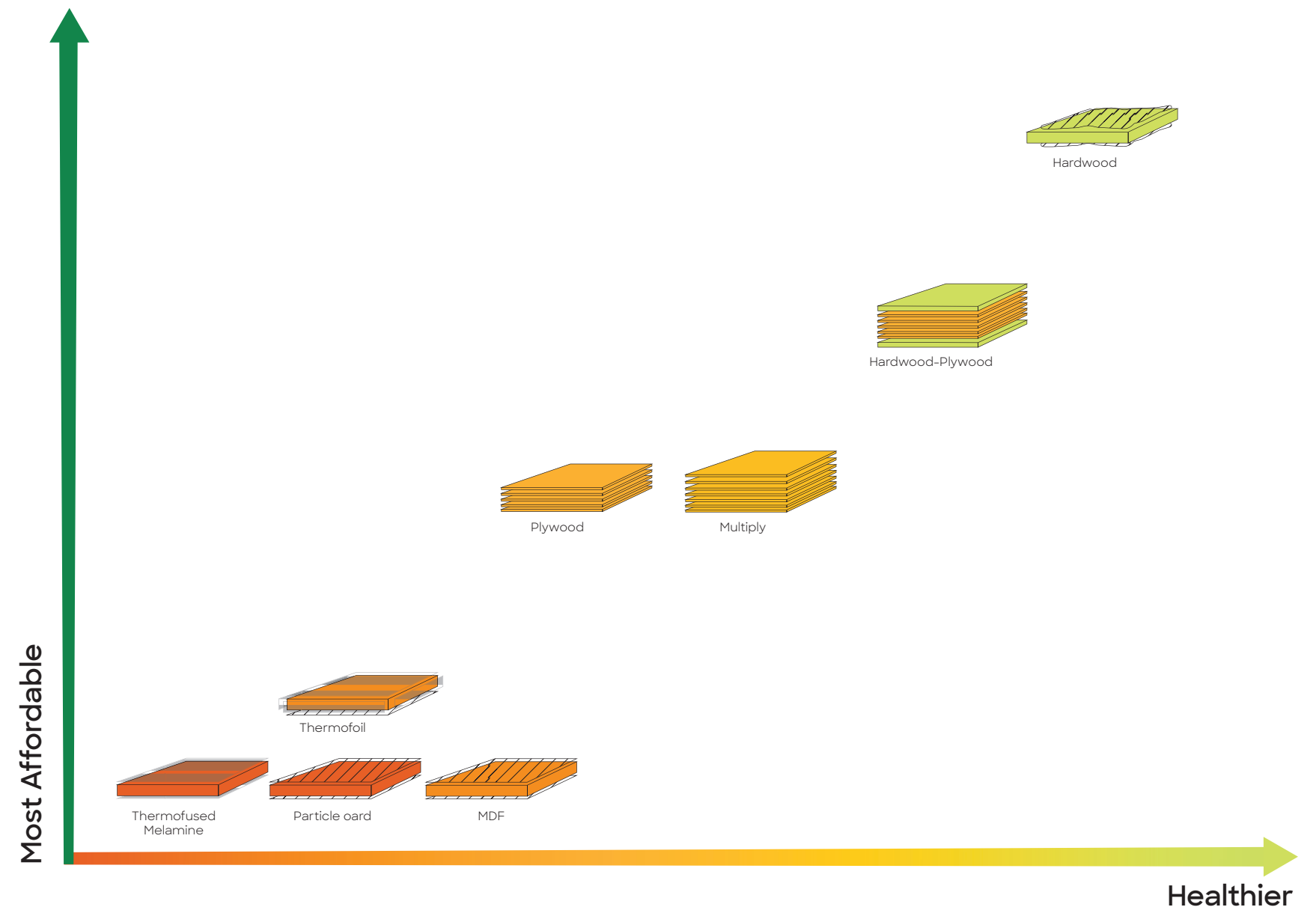



Thermofused Melamine Cabinetry

This is one of the most commonly installed cabinets because of its affordability. It can be easily maintained when it is new, but has a relatively short life span. Thermofused Melamine is paper saturated with **formaldehyde resin** and fused onto MDF or particle board. In most cases, binders in MDF are forms of polyurethane (TDI, HDI, MDI or PMDI) which contain **isocyanates**.

Health impacts:

Formaldehyde is a colorless gas (one of the most common VOCs). **Phenol formaldehyde**, **urea formaldehyde**, and **melamine formaldehyde** are all known to release (off-gas) formaldehyde long after product installation. Formaldehyde exposure is linked to myeloid leukemia and rare cancers, eye and nose irritation, lung irritation, and skin irritation like eczema.

Isocyanates are powerful irritants to the mucous membranes of the eyes and gastrointestinal and respiratory tracts. These chemicals are linked to cancer as well as respiratory illnesses.

Here's what you should know. Thermofused melamine cabinets:

- Are an affordable option.
- Have a relatively short lifespan of 10 years.
- Are easy to clean when they are new, but quickly deteriorate through chipping and water damage.
- Are vulnerable to scratches, chips, and burn marks from everyday use.
- Can chip easily, especially in the corners, and the damage is difficult to repair.
- Are susceptible to damage when exposed to water and high humidity, making the MDF core swell and impossible to repair.
- Cannot be re-sanded or resurfaced when damage occurs.
- Ultimately must be replaced when damaged, and they end up in a landfill.

5% of material content is healthier



Health & Affordability Material Matrix

Highlighted materials are used in this cabinet type

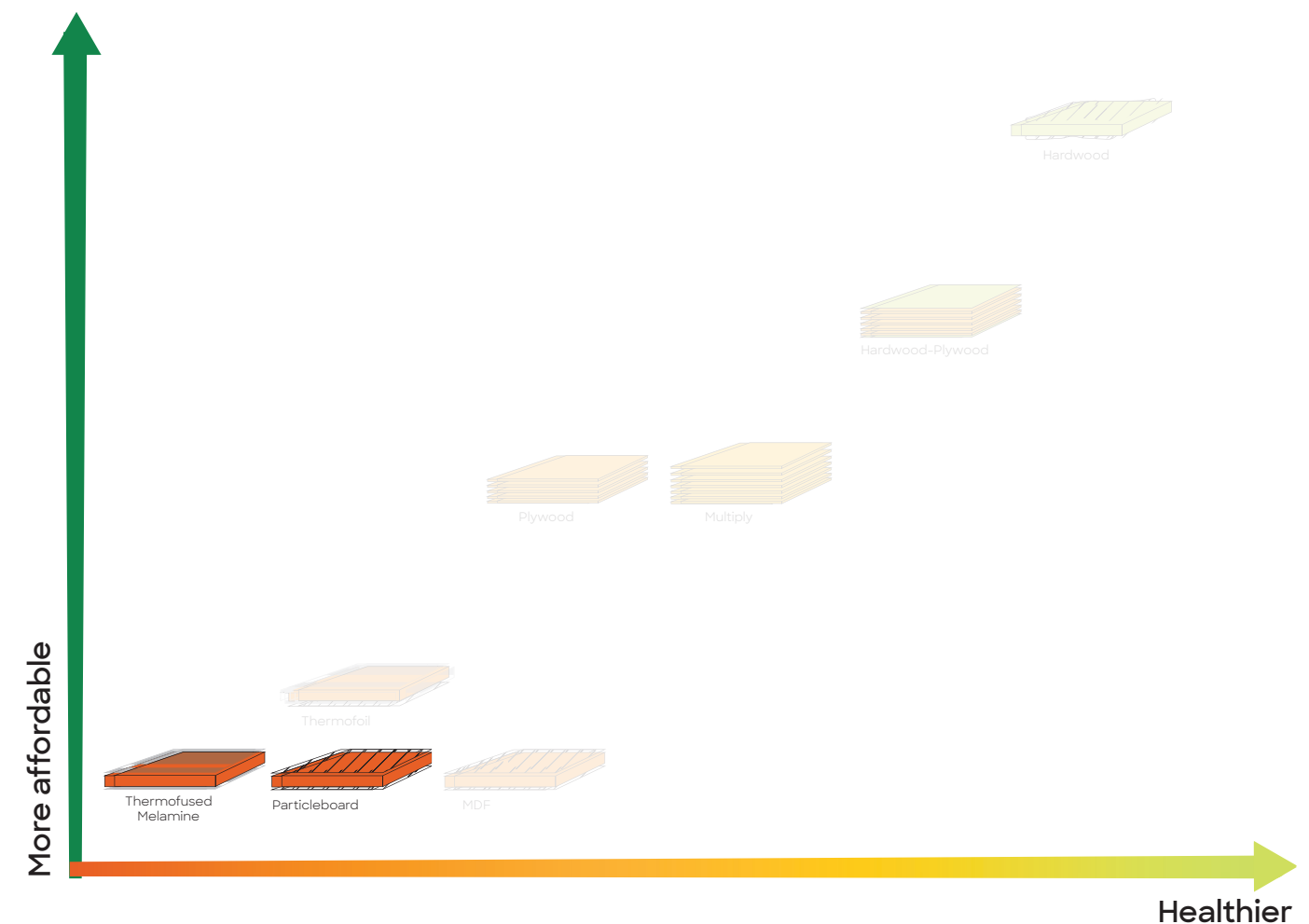

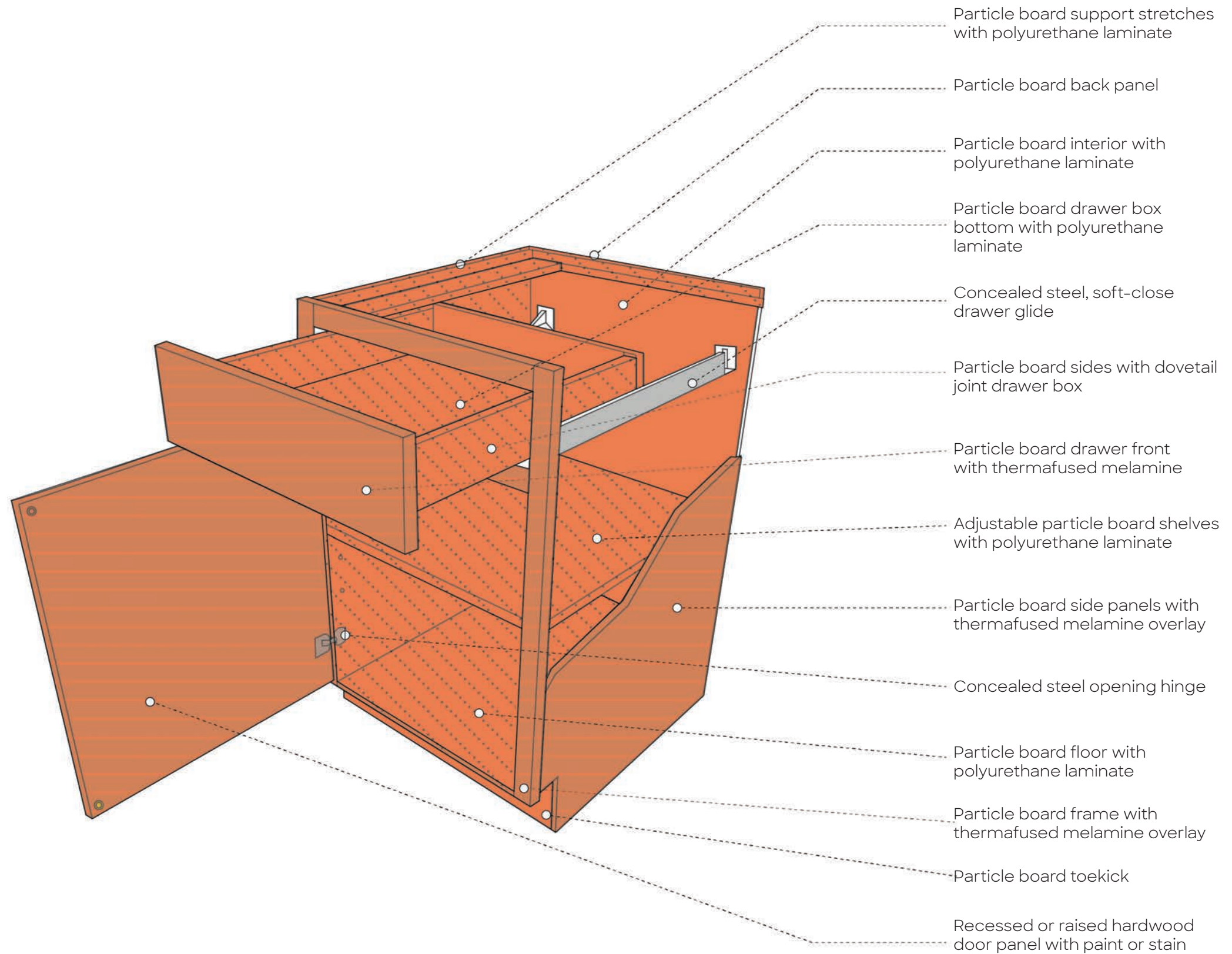
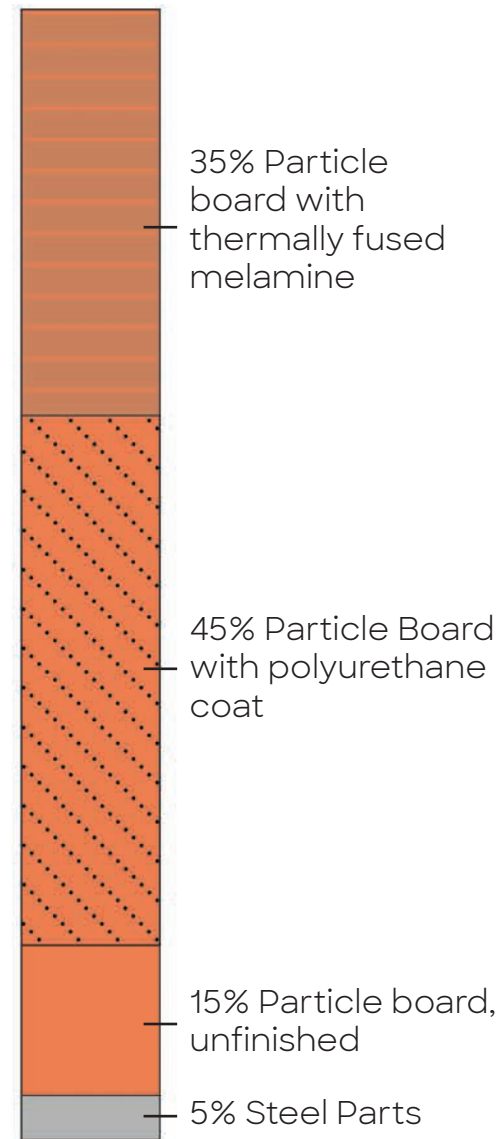

Thermofoil Laminate Cabinetry

This is one of the most commonly produced cabinets because of its affordability. It can be easily cleaned in the first years after installation, but has a relatively short life span of only 10 years. In addition, materials in its composition are linked to negative health effects. Thermofoil laminate is a thin layer of vinyl (PVC) that is vacuum-pressed on MDF. In most cases, binders in MDF are forms of polyurethane (TDI, HDI, MDI or PMDI) which contain isocyanates.

Health impacts:

Toxics are released from both the vinyl laminate and the binder in the MDF core. Polyvinyl Chloride (PVC) is a known human carcinogen and contains harmful plasticizers, such as phthalates, that can disrupt the endocrine system, the body's system of regulating hormones. Phthalates are linked to: childhood asthma and allergies, ADHD, low sperm count and low testosterone, male genital birth defects, early puberty in girls, and higher breast cancer risk.

Isocyanates are powerful irritants to the mucous membranes of the eyes and gastrointestinal and respiratory tracts. These chemicals are linked to cancer as well as respiratory illnesses.

Here's what you should know. Thermofoil laminate cabinets:

- Are an affordable option.
- Have a relatively short lifespan of 10 years.
- Are easy to clean during the early years of their lifespan, but quickly deteriorate through chipping and water damage.
- Are especially prone to delamination and peeling due to moisture and heat exposure.
 - If installed too close to a heat source like an oven, toaster, or coffee maker, the vinyl coating may pull away from the core.
 - Water damage and high humidity make the MDF core swell and impossible to repair.
- Can chip easily, especially on the corners, and the damage is difficult to repair.
- Are challenging to repurpose or repair when damaged, and they end up in a landfill.

5% of material content is healthier



Health & Affordability Material Matrix

highlighting materials used in this cabinet type

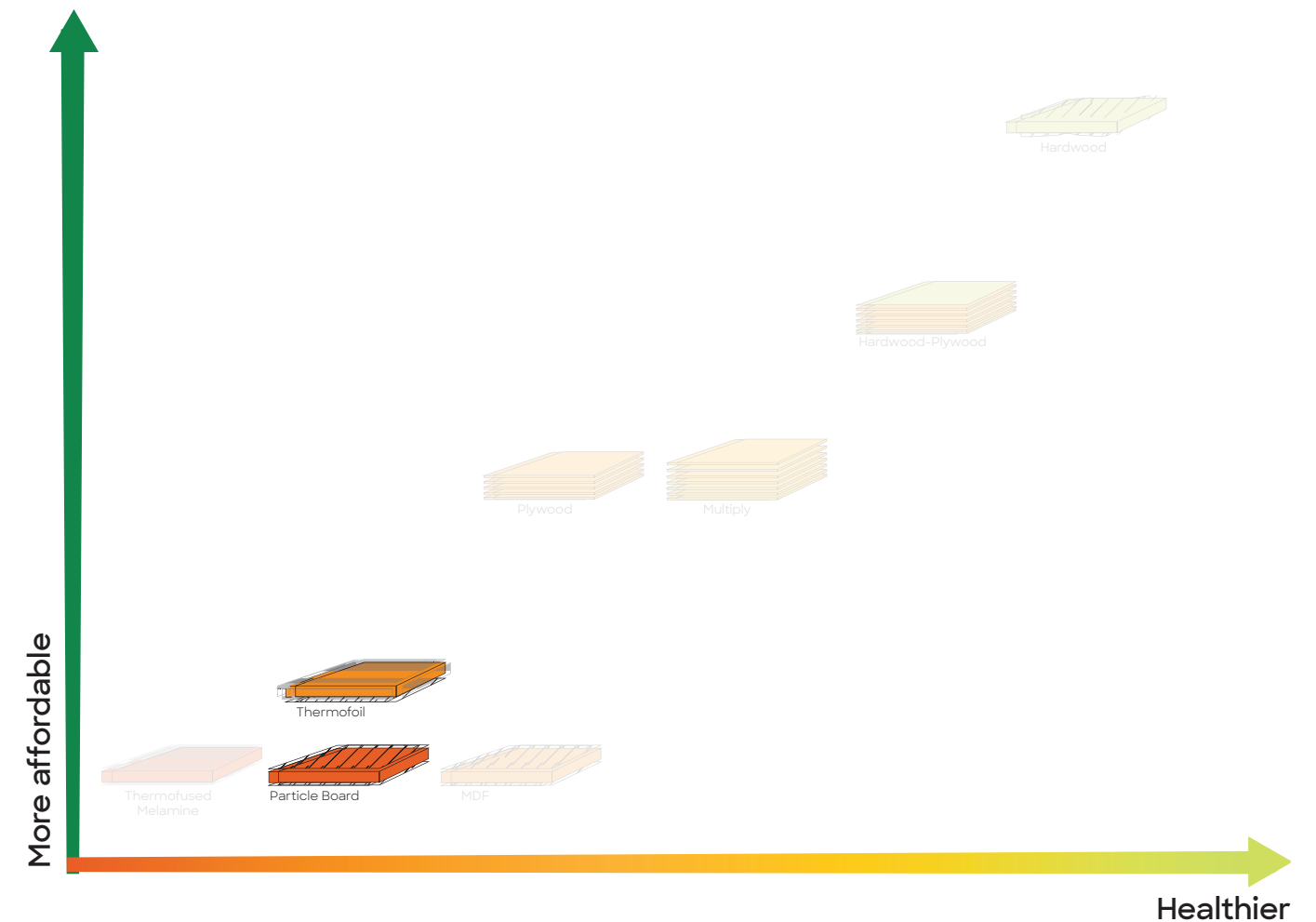

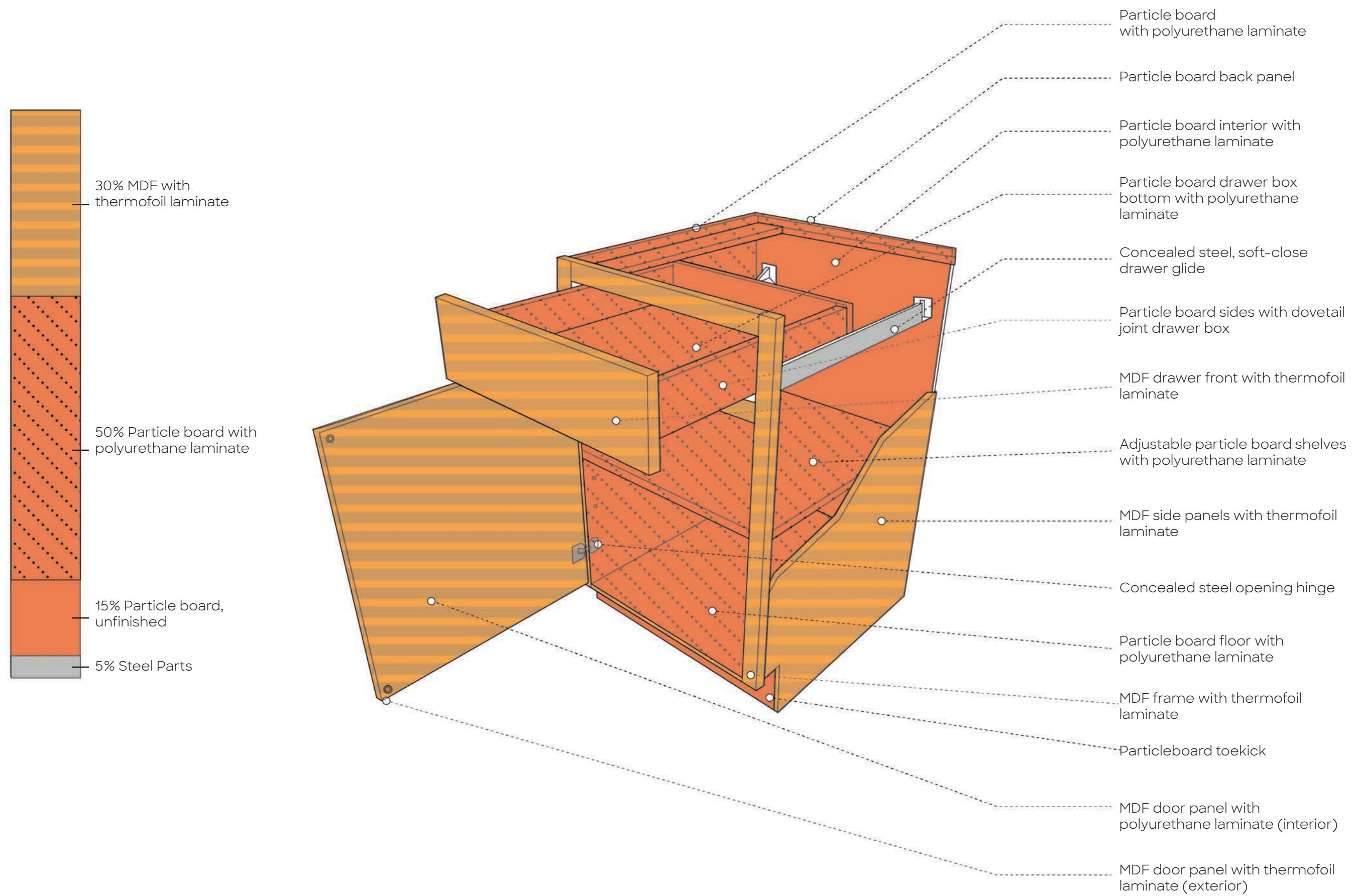

30% MDF with thermofoil laminate

50% Particle board with polyurethane laminate

15% Particle board, unfinished

5% Steel Parts

Particle board with polyurethane laminate

Particle board back panel

Particle board interior with polyurethane laminate

Particle board drawer box bottom with polyurethane laminate

Concealed steel, soft-close drawer glide

Particle board sides with dovetail joint drawer box

MDF drawer front with thermofoil laminate

Adjustable particle board shelves with polyurethane laminate

MDF side panels with thermofoil laminate

Concealed steel opening hinge

Particle board floor with polyurethane laminate

MDF frame with thermofoil laminate

Particleboard toekick

MDF door panel with polyurethane laminate (interior)

MDF door panel with thermofoil laminate (exterior)

Particle Board Cabinetry

This is one of the most commonly produced cabinets because of its affordability, but also has one of the shortest life spans. Particle board is made from wood chips or shavings combined with a resin or glue binder, compressed into panels, and often finished with veneer or laminate. This product can be unhealthy because of formaldehyde found in the binders.

Health impacts:

Formaldehyde is a colorless gas (one of the most common VOCs). Phenol formaldehyde, urea formaldehyde, and melamine formaldehyde are all known to release (off-gas) formaldehyde long after product installation. Formaldehyde exposure is linked to myeloid leukemia and rare cancers, eye and nose irritation, lung irritation, and skin irritation like eczema.

Here's what you should know. Particle board cabinets:

- Are an affordable option.
- Have a very short lifespan (a maximum of 5 years) compared to other cabinets.
- Easily warp and swell when exposed to humidity and moisture.
 - This is especially common for cabinets located above the stove and near the sink.
- Are not strong or durable when compared to solid wood, plywood, and MDF.
- Are heavy compared to plywood, making them more difficult to install.
- Are unable to support heavy loads and may eventually break from the weight of common kitchen items like pots, pans, canned goods, etc..
- Ultimately must be replaced when damaged, and they end up in a landfill.

25% of material content is healthier



Health & Affordability Material Matrix

highlighting materials used in this cabinet type

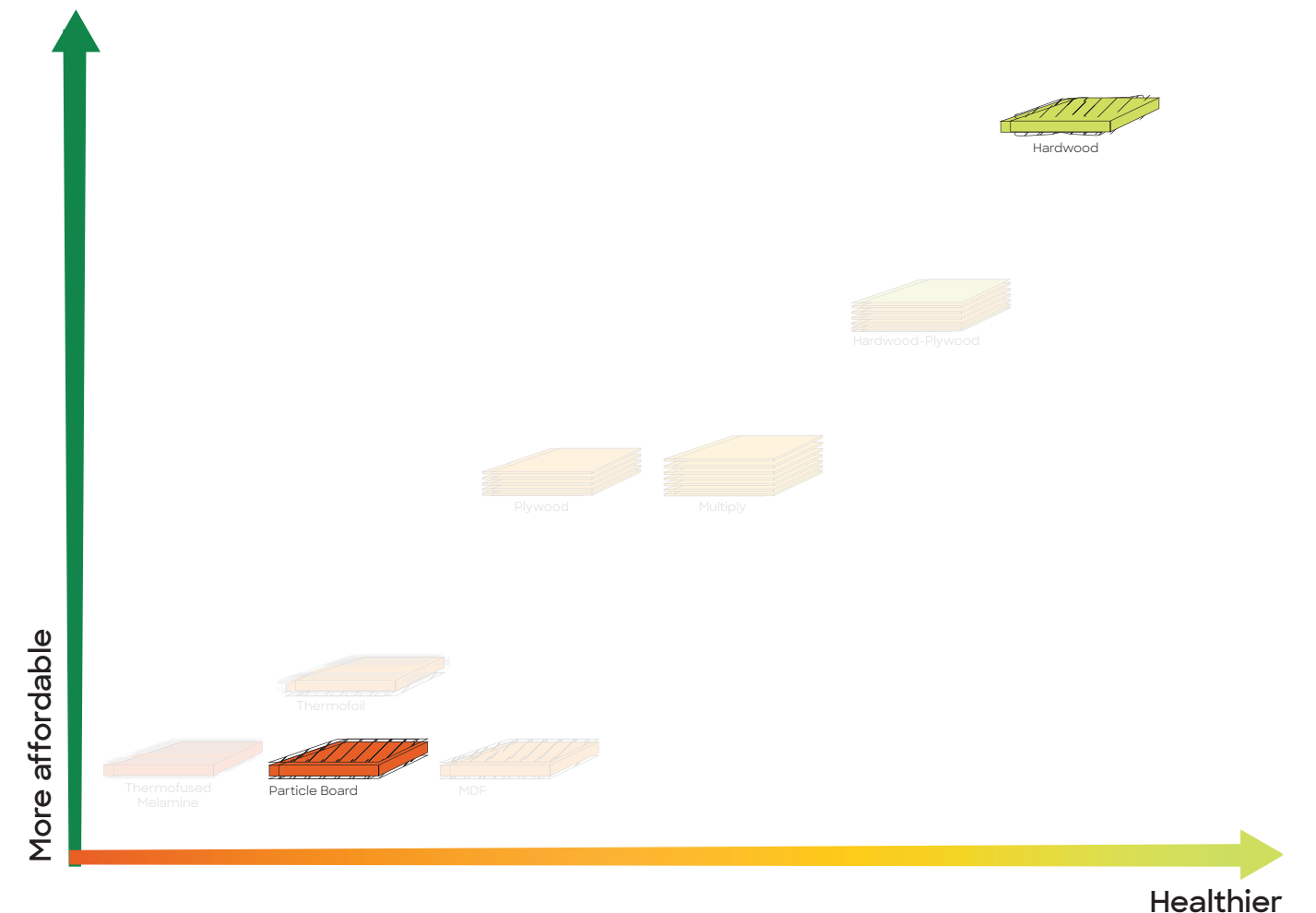

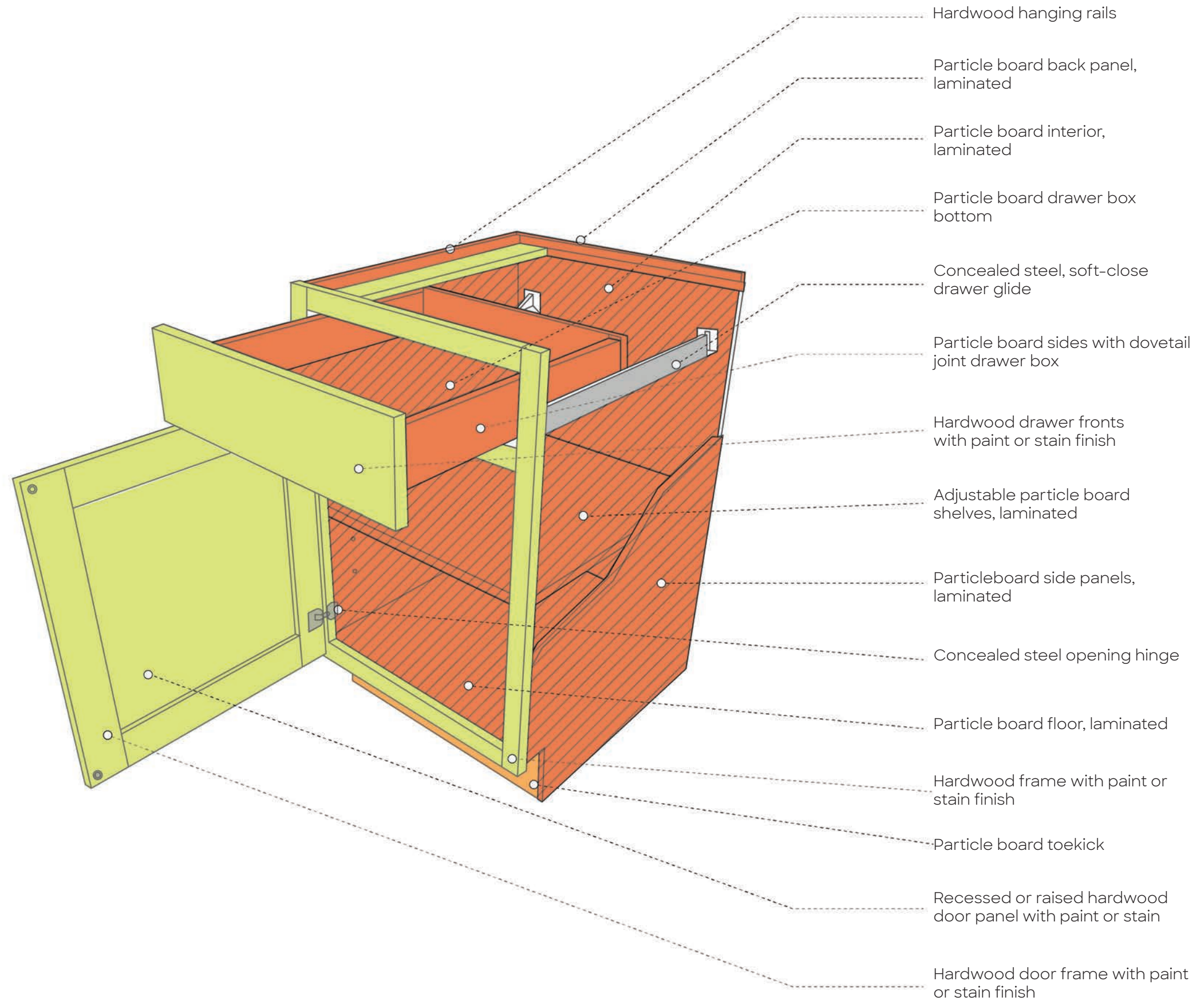
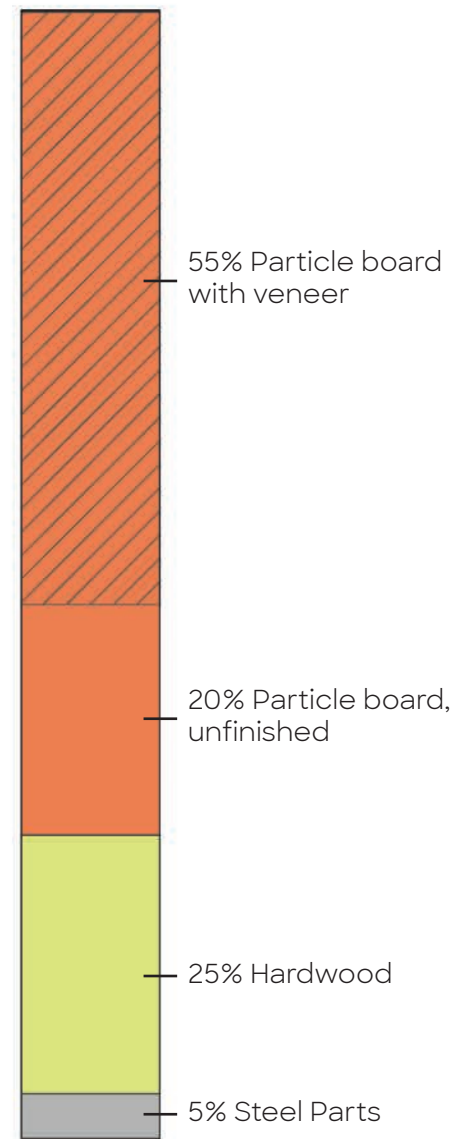

Plywood Cabinetry

Although more expensive than cabinets predominantly built of particle board or MDF, plywood cabinets are significantly more durable and have a much longer lifespan than most cabinetry. Plywood is made up of numerous layers of thin wood veneer that are glued together and compressed between a face veneer. For stability, each layer is rotated 90° from the one beneath it. The greater the number of layers, the more durable but more expensive. It can be considered unhealthy if the binder contains **formaldehyde**. Soy-based binders are used as a healthier alternative.

Health impacts:

Formaldehyde is a colorless gas (one of the most common VOCs). **Phenol formaldehyde**, **urea formaldehyde**, and **melamine formaldehyde** are all known to release (off-gas) formaldehyde long after product installation. Formaldehyde exposure is linked to myeloid leukemia and rare cancers, eye and nose irritation, lung irritation, and skin irritation like eczema.

Here's what you should know. Plywood cabinets:

- Are a more expensive option compared to particle board or MDF.
- Have a long lifespan of 10-25 years, depending on how much moisture they encounter.
- Can handle the weight of countertops, dishes, and doors without sagging or bowing.
- Are lighter in weight than MDF and particle board, making them easier to install for wall cabinets.
- Are generally moisture resistant compared to MDF or particle board.
 - They don't split, warp, or expand unless they endure long term water exposure.
- Hold nails, screws and other fasteners very well.
- Can be refinished with light sanding.
- Can be designed for disassembly to allow for reuse of materials.

30% of material content is healthier



Health & Affordability Material Matrix

highlighting materials used in this cabinet type

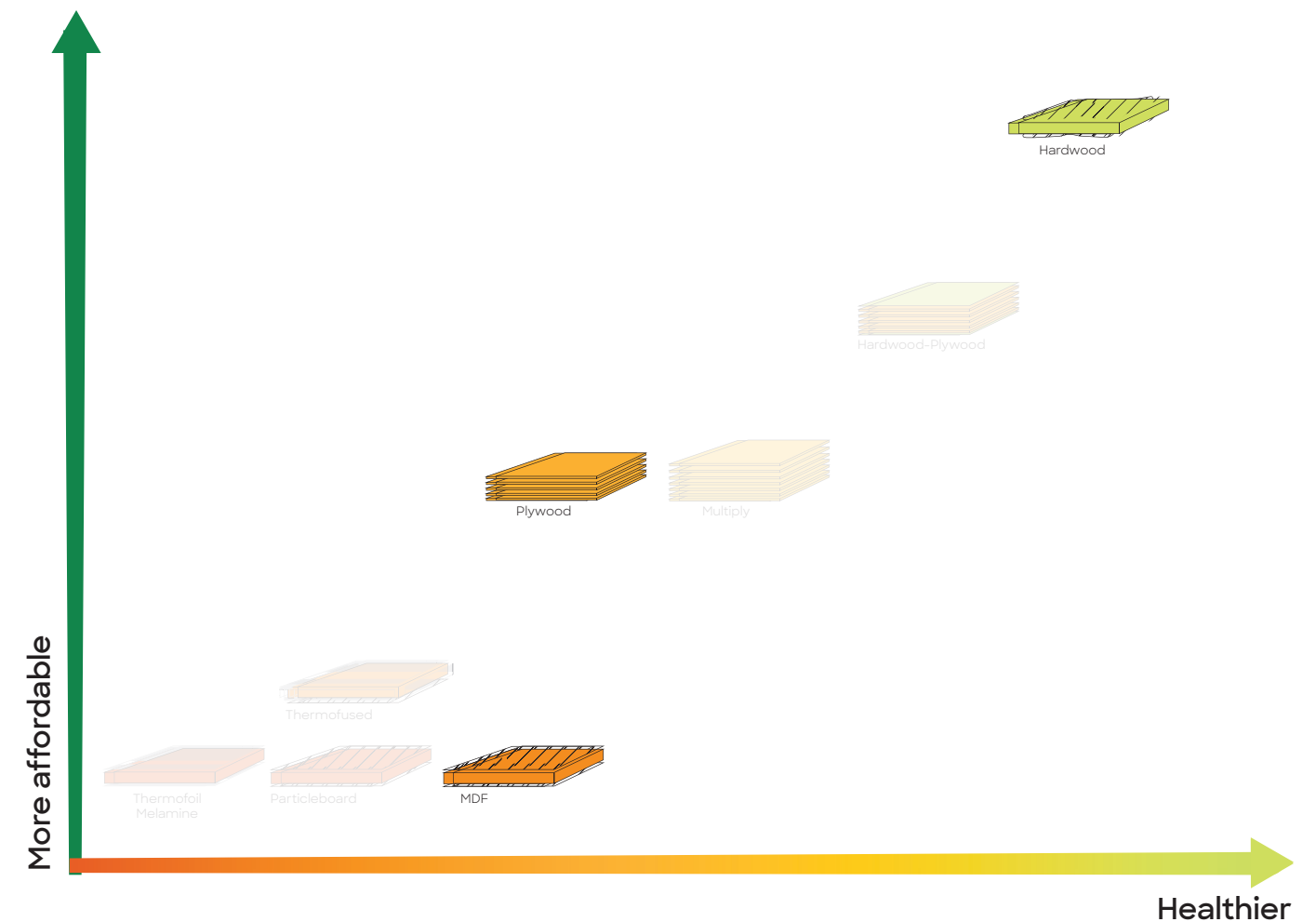

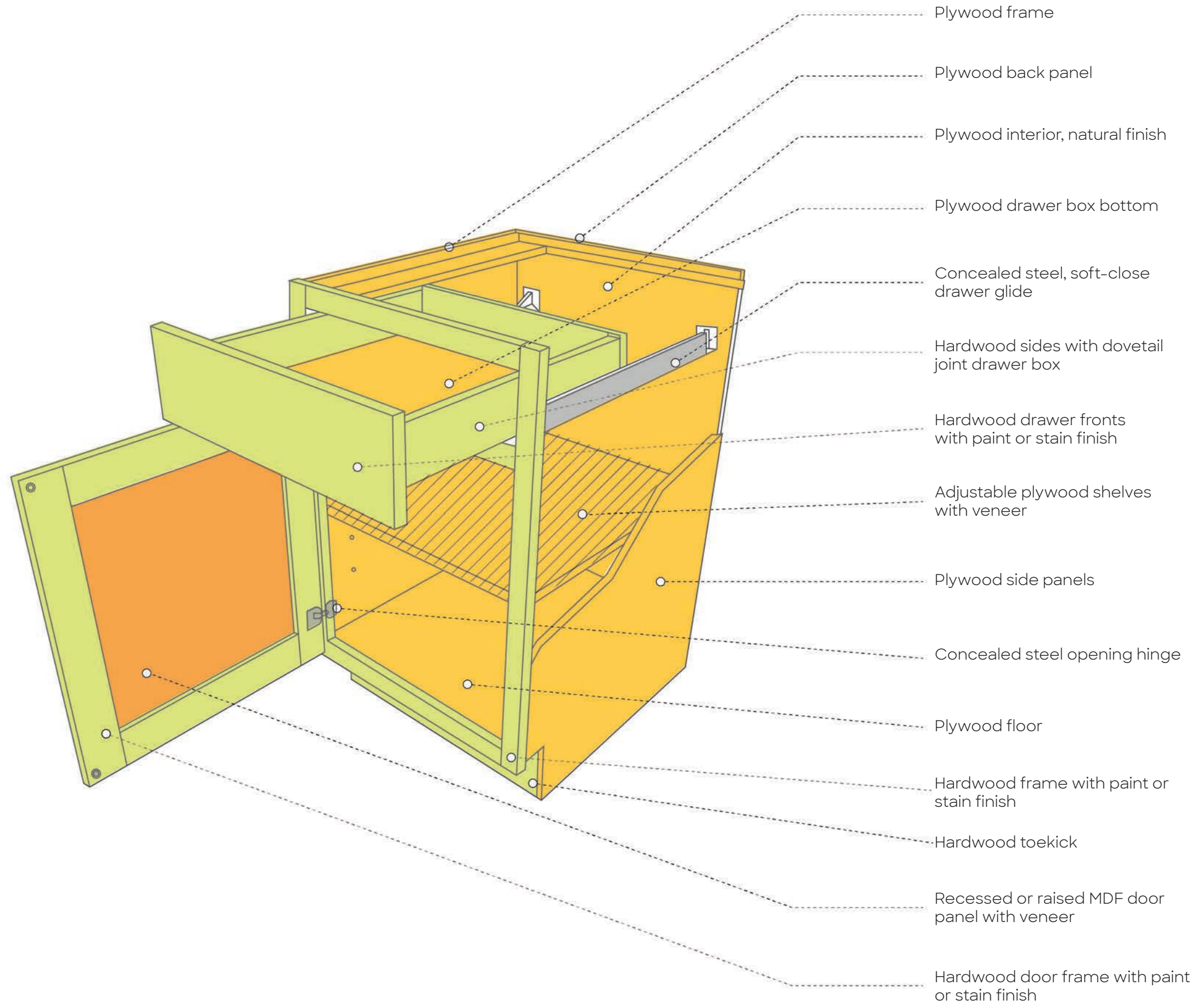
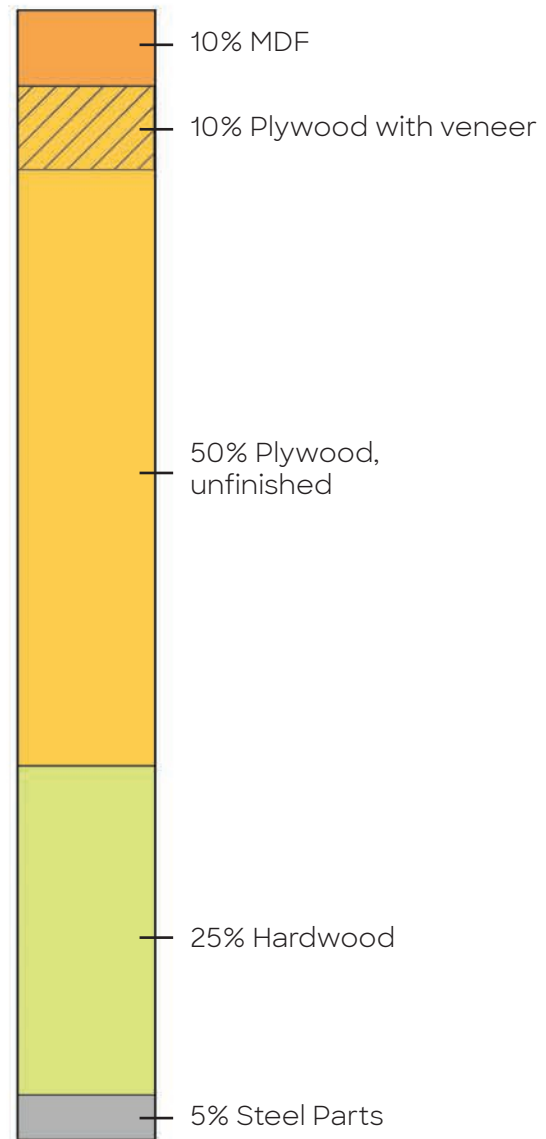

Durable Cabinetry

This type of cabinetry made from hardwood plywood is used in locations where there is a need for longevity such as public housing. This is a more affordable option than solid wood cabinetry, but has similar durability. Hardwood-plywood is usually made of a plywood core that is compressed between 1/8" thick hardwood veneer. Because of the thicker hardwood veneer, this material is often more durable and can be refinished more easily, but is also more expensive. A particleboard or MDF board core is less expensive, but an MDF core is heavier and less malleable. As with other composite wood products, the binders are typically toxic resins containing **formaldehyde**.

Health impacts:

Formaldehyde is a colorless gas (one of the most common VOCs). Phenol formaldehyde, urea formaldehyde, and melamine formaldehyde are all known to release (off-gas) formaldehyde long after product installation. Formaldehyde exposure is linked to myeloid leukemia and rare cancers, eye and nose irritation, lung irritation, and skin irritation like eczema.

Here's what you should know. Durable cabinets:

- Are a more expensive option compared to particle board or MDF.
- Have a long lifespan of 10-25 years, depending on care and moisture management.
- Can handle the weight of the countertops, dishes and doors without sagging or bowing.
- Are lighter in weight than MDF and particle board, making them easier to install for wall cabinets.
- Are generally moisture resistant.
 - They don't split, warp, or expand unless they endure long term water exposure.
- Can hold nails, screws and other fasteners very well.
- Can be easily refinished due to thicker veneer.
- Can be designed for disassembly to allow for reuse of materials.

30% of material content is healthier



Health & Affordability Material Matrix

highlighting materials used in this cabinet type

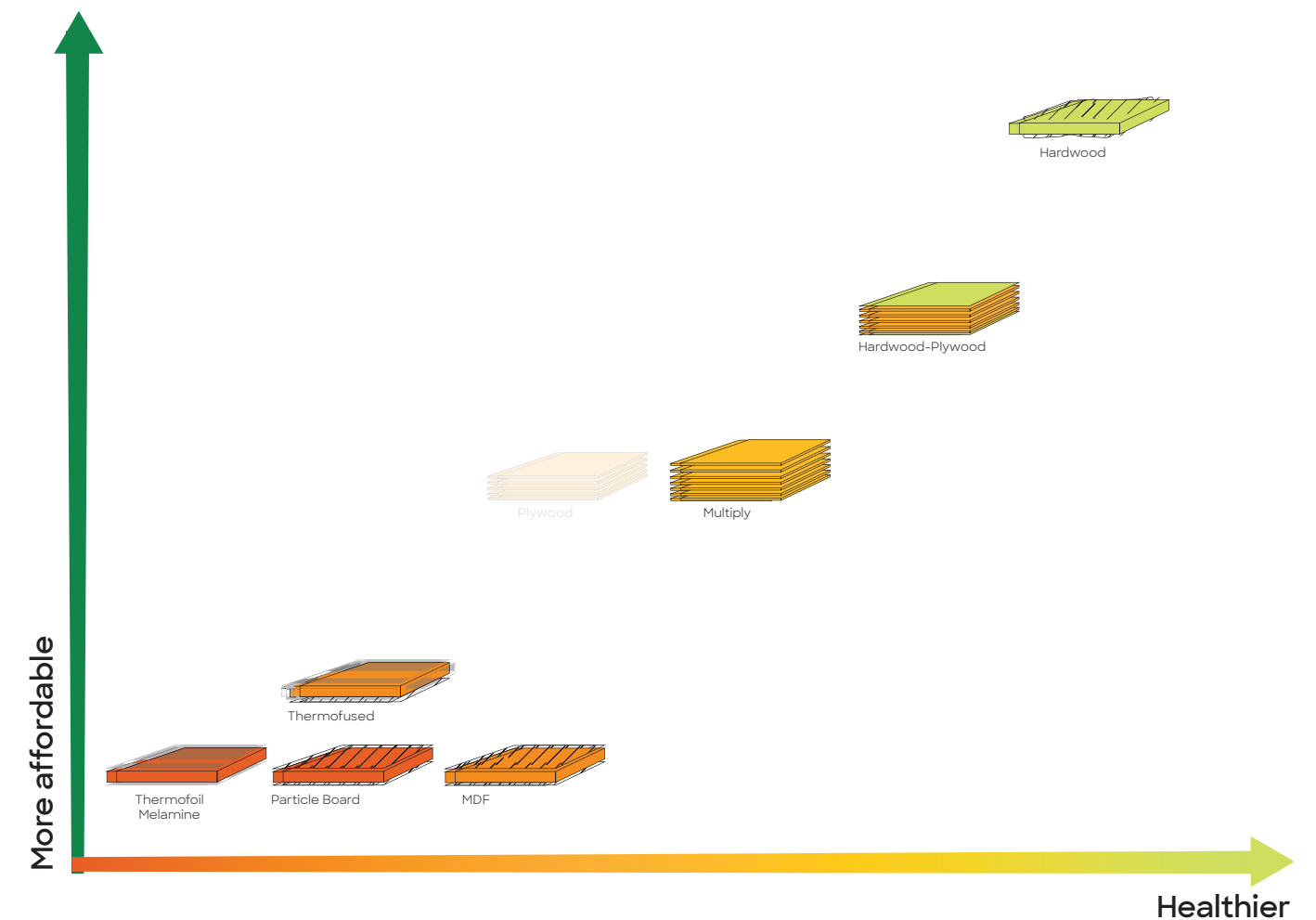

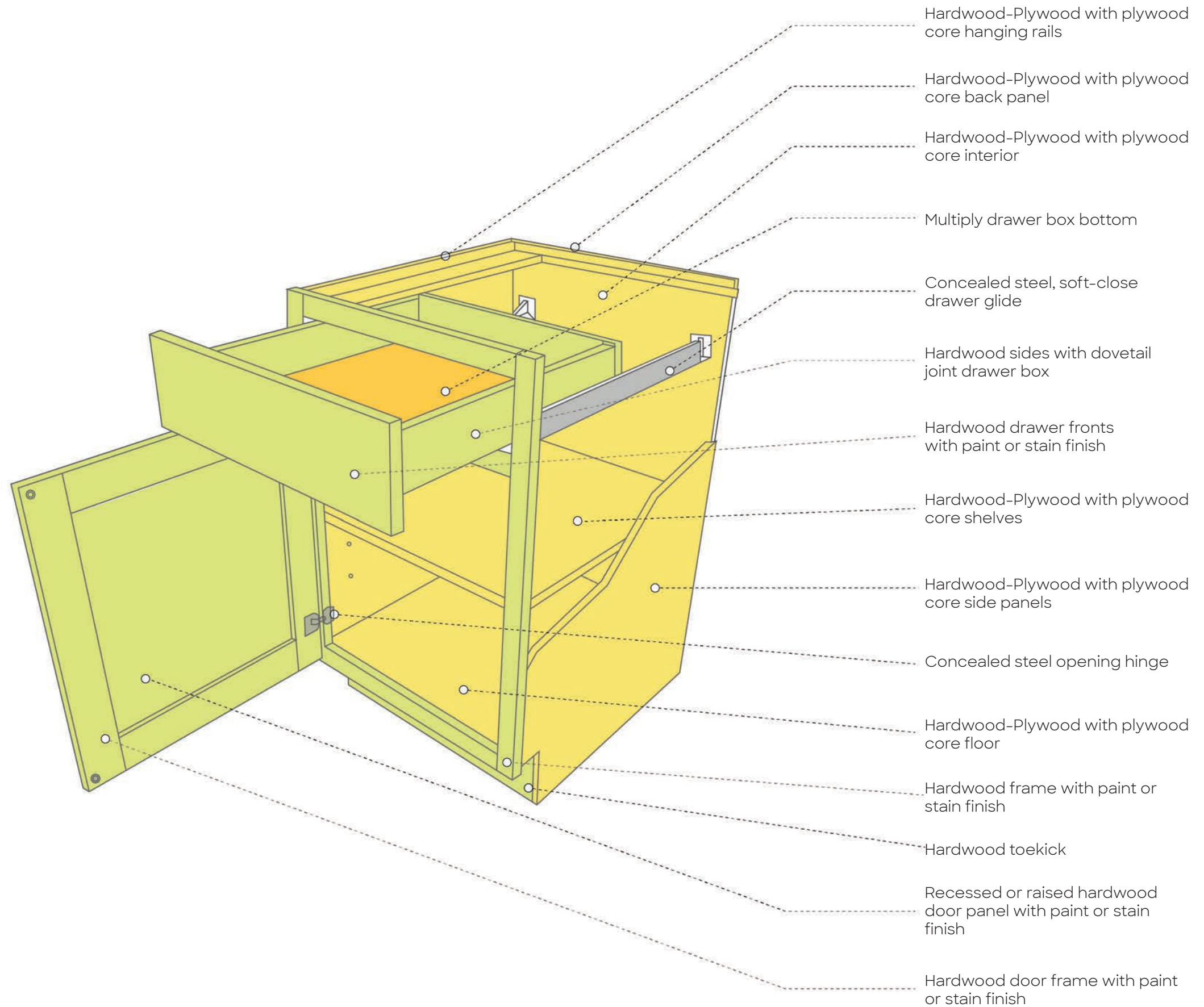
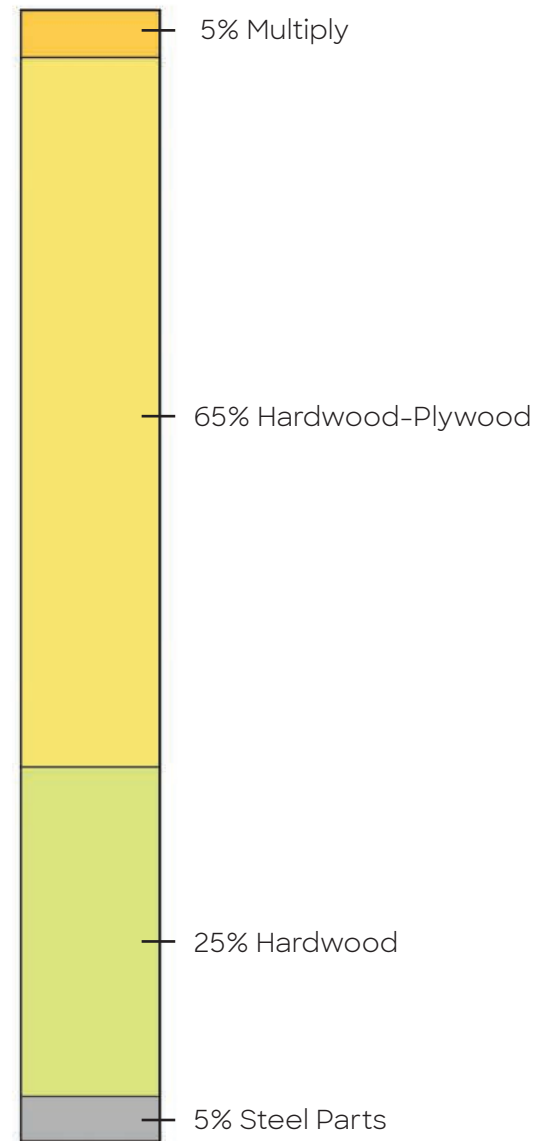

Hardwood Cabinetry

Although one of the most expensive types of cabinetry, hardwood cabinetry is known for its durability and longevity. Hardwood panels consist of a core made from either softwood or hardwood which can be faced and backed with a stain or laminate. It can be used in several ways but it's often used as the framing and facing of cabinetry. This the healthiest option available, when healthier finishes are applied. In addition, FSC-certified options ensure that sustainable forestry practices were employed when harvesting the trees.

Health impacts:

Solid wood has minimal negative health impacts if finished without harmful additives often found in solvents or drying accelerators. Long term exposure to solvents have been linked with cancer and asthma. Read our [alternative finishes spec guidance here](#).

Here's what you should know. Hardwood cabinets:

- are a more expensive option and have lasting durability.
- can last for decades.
- are able to be refinished easily.
- can warp and crack with increased temperatures and humidity.
- needs a healthy finish option to withstand long term exposure to water and moisture.
- if left unfinished are vulnerable to bug infestation.
- can be designed for disassembly to allow for reuse of materials.

30% of material content is healthier



Health & Affordability Material Matrix

highlighting materials used in this cabinet type

